

American Safe Room, Inc.
Operation Manual
for the
ASR-50-BB
Emergency Hand Pump

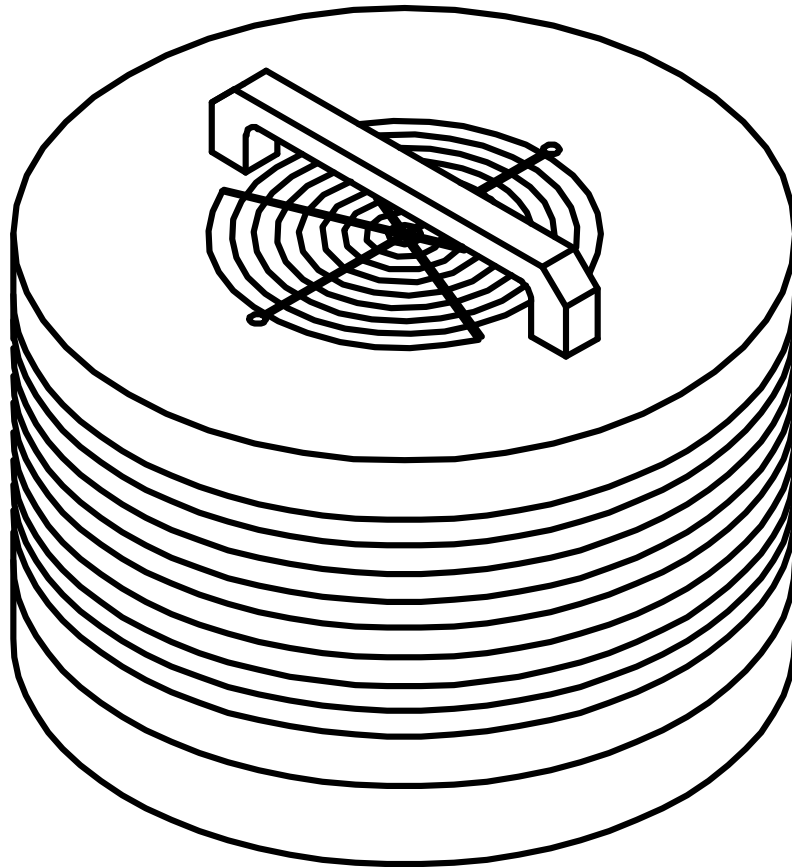

Revision (E)
August 12, 2007

Table of Contents

Description	3
Operation with ASR-48-NBC and ASR-100N-NBC	3
Operation with ASR-100	3
Size, weight, and stroke length.....	5
Parts	6

Description

The ASR-50-BB Emergency Hand Pump will introduce safe, breathable air into your protected space when all other electrical supply apparatus has failed: the power grid and the capacity of the battery backup has been exhausted. On the models of the Safe Cell which have the internal power supply that automatically charges the user-supplied battery and then automatically reverts to the battery power in the event of a power outage, the battery will last from 16 to 24 hours — allowing you to go to sleep knowing that your Safe Cell will operate if the line power fails. After that, it will take mechanical force to introduce safe, breathable air into your protected space. The ASR-50-BB Emergency Hand Pump will provide you with the means to do this.

It will slip-fit onto any Safe Cell in a matter of seconds.

It is a hand-operated reciprocating pump with an output of 1,216 cubic inches (19,927 cubic centimeters) per 10.75-inch/27-centimeter stroke.

Operation procedure for ASR-48-NBC and ASR-100N-NBC Safe Cells with the internal blower:

1. If the Safe Cell is mounted high on the wall, remove it by unscrewing the two black plastic hand nuts connected to the quick release bracket and clamp assembly. This places the pump operating handle at waist height for sustained ergonomic operation.
2. Set the filtration unit on the floor.
3. Insert the tapered female receiver of the manual hand pump over the male coupler of the filtration unit.
4. Using a slight twisting motion, make sure the bellows is correctly seated, not more than 5-pounds /2 kilogram force is required — this is a “slip fit” using hand power only.

Operation procedure for ASR-100 series with the external blower.:

1. If you have a high, wall mounted ASR-100, first follow steps 1 and 2 from above.
2. Remove the blower unit from the filtration unit by lifting it straight up out of its quick disconnect socket — a slight twisting motion might help. This places the pump operating handle at waist height for sustained ergonomic operation.
3. Insert the tapered female receiver of the manual hand pump over the male coupler of the filtration unit.
4. Using a slight twisting motion, make sure the bellows is correctly seated, not more than 5-pound US/2 kg force is required.

Size, weight, and stroke length

Size: 12-inch diameter/304-mm, having a 7-inch/179-mm stroke
Weight: 8-pounds/3.6-kilograms

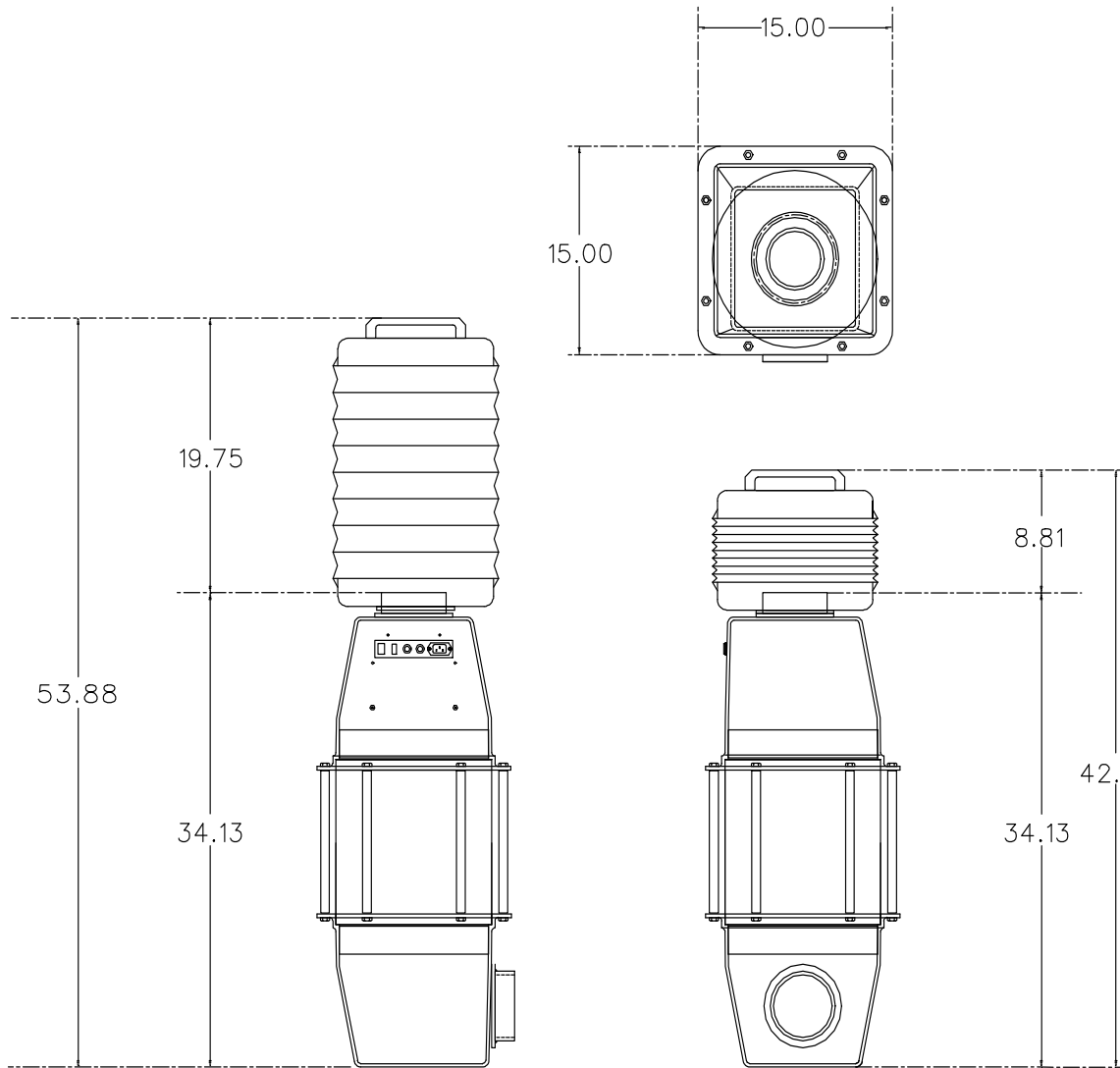

Parts

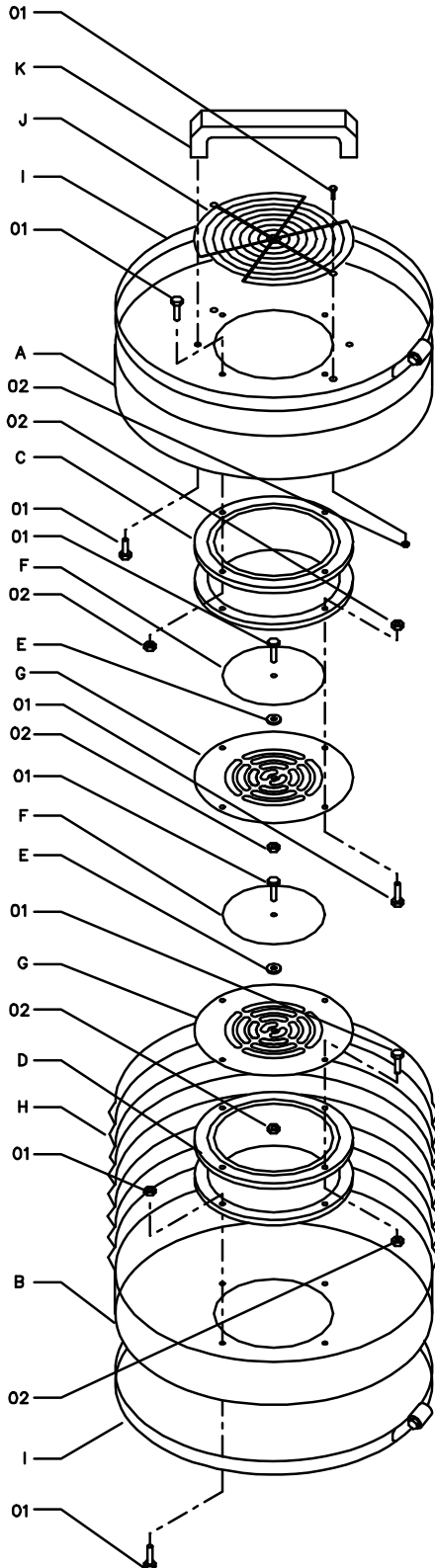

Item	Qty	Description	Part No.
01	24	Sloted cap screw 10-24 x 1/2 lg.	
02	24	Hex nut 10-24	
A	1	End cap, exhaust	30002-13
B	1	End cap, intake	30002-13A
C	1	Valve body, exhaust	30002-03A
D	1	Valve body, intake	30002-03B
E	2	Washer, rubber	00000-00
F	2	Flapper, valve	00000-00
G	2	Seat, valve	10311-41
H	1	Bellows	12-R2 blu
I	2	Clamp, hose	63208
J	1	Guard, hand	CFG-160
K	1	Handle	DUH-35

